

UPDATES ON GEARED VS GEARLESS DRIVE SOLUTIONS FOR GRINDING MILLS

R. Kalra, CITIC-HIC Pty Ltd, Sydney, NSW, Australia
J. Jiangang, CITIC Heavy Industries Co., Ltd, Luoyang, Henan, China
I. Druce, CITIC-HIC Pty Ltd, Sydney, NSW, Australia
M. Rauscher, CITIC-HIC Pty Ltd, Sydney, NSW, Australia

ABSTRACT

The current paper looks at evaluating the merits of large geared mills versus gearless driven mills by evaluating the following factors:

- The capability of currently available systems in terms of power and mill diameter
- Efficiency in terms of overall electrical power consumed vs mechanical output power
- Capital cost
- Running costs
- Cooling requirements in terms of air versus water cooling
- Installation and delivery time
- World's largest geared drive – 2x8500kW – Wushan, China (operating)

Among the many reasons that geared drives on large SAG mills are not favoured, is due to not having an efficient variable speed drive option (60 to 80% critical speed), which is required for process reasons. As technological advances have occurred quite rapidly in recent years, this paper uses the latest data in applying these comparisons and attempts to dispel some of the myths regarding Slip Energy Recovery (SER) and variable frequency drive technology on twin pinion drive systems. Early attempts to provide load sharing on twin pinion drives used primitive electronics which have since been developed to eliminate the problems encountered in earlier attempts. In particular, torque pulsations between the twin motors have been overcome using a higher number of devices (pulses) and better electronics. With successful operation of 2 x 6.5MW (Phu Kham, Laos) and three 2 x 7MW units under manufacture (Pascu Lama) and a further 40 projects worldwide, energy efficient Hyper Synchronous SER drives are now mature and ready for use on 2 X 10MW dual drive mills. Speed variation required is in the range of +/- 15% of synchronous motor speeds. VVVF drive packages from ABB and Siemens are also available for 2 x 10MW in low and high speed options. Dual hydraulic inching drives provide a much safer and convenient operation with the added advantage of locked charge detection.

INTRODUCTION

Over the last several years, one of the biggest decisions that face the customers has been what type of drive system best suits their particular application. There has been a great deal of confusion particularly in terms of efficiency, durability, availability and value for money. This paper attempts to clear up this confusion using accurate information obtained from our own recent projects.

HISTORY

Girth gear drives have been, and continue to be, the primary method of driving SAG mills, Ball mills and other rotating elements. Several thousand grinding mills have been manufactured and have been in operation for the last century. The gearless drive came into the minerals industry in 1980 and as per their reference lists, Siemens have approximately 60 installations and ABB have approximately 85. The reasons why these gearless drives on mills came about in the late 1970's is because of SAG mills requiring variable speed and the

limitations of material of construction and the heavy manufacturing capabilities at the time. Girth gears have been going through enormous improvements over time following the use of FEA, casting software like MAGMA (using full ring risers with solidifications & cooling), ultrasonic testing and special materials of construction with improvement of hardness to 325BHN. Forged steel with ASTM standard materials and ultrasonic testing have improved the overall gear-set design capability. Some consultants have the view that the gear drive is limited in power. Mr Craig Denecki (Falk Milwaukee) in his paper, presented at the 1996 SAG mill conference, provided details of the then largest gear drive in operation on a SAG mill (34ft x 18ft) at Escondida 13.4MW, which began operation in 1995. The reason for not having larger gear drives was due to the limitation of gear manufacturers not having access to larger single piece special alloy castings. **To the benefit of consumers CITIC HIC has now overcome this limitation and mine operators can now consider more cost effective larger gear driven mills. The World's largest gear driven mill (manufactured at CITIC HIC) is now operating at Wushan Phase II (Ball Ø7.9m x 13.6m – 17MW- 2x8500kW)**



Figure 1. Gearless Mill Drive.

DESIGN

Materials of construction - gear & pinion

Based on over 50 years of casting, heat treatment, machining, gear cutting and feedback from operating equipment, CITIC HIC have three different Chrome, Nickel and Molybdenum cast steel materials of construction. This cast material provides sufficient hardness in the root of the teeth and satisfies the strength requirements. Rolled forgings & plates are not preferred due to the grain structure aligned in the rolling direction. Castings provide an isotropic structure (not directional). The optimum design of the girth gear geometry considered by the design engineering team includes questions on material properties, module, pressure & helix angle, tooth width, flank contact pressure, pitch circle

of pinion and axial forces. For mill drives a 25° pressure angle is preferred as it is approximately 10% stronger than a 20° pressure angle. Also the helix angle is limited to 7.5° to keep control on the axial forces. Spur gears with double meshing pinions drives are not preferred for large mill drives as a single helical gear has more than 50% rating than an equal sized spur gear. A single helical gear is quieter and will last longer than a comparable spur gear because of the helical action.



Figure 2. Wushan Phase II.

Use of international standards for gear design – AGMA6114 – 2006 (metric)

Single helical mill gear set calculations are carried out using AGMA6114-2006 (metric) design standard. The AGMA6004 – F88 standard was released in 1988 which applied to all large spur and helical gears. For the same drive a calculation in accordance with AGMA6004 permitted increased power transmission by approximately 10%. This standard has since been withdrawn and presently the new applicable standard is AGMA6114 – 2006 (metric). This new AGMA standard gives very slightly higher power transmission than AGMA321.05. Adequate operating experience can only be expected after 10-15 years. AGMA321.05 1970 standard is still valid today for reference purposes. There are other conditions to consider namely installation, operating, climate and selection of suitable lubricant.

FEA (finite element analysis)

Design of the gear under load needs to be supported by a suitable structure which is attached to the grinding mill body. Hence the use of FEA is done in-house. This includes evaluation of pinion and tooth deflection under load. This FEA is done on nearly all CITIC HIC mills.

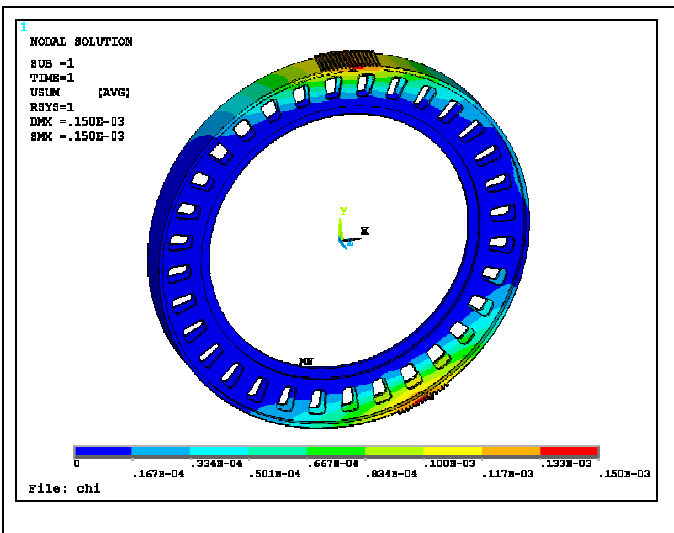

Figure 3a. Gear FEA.

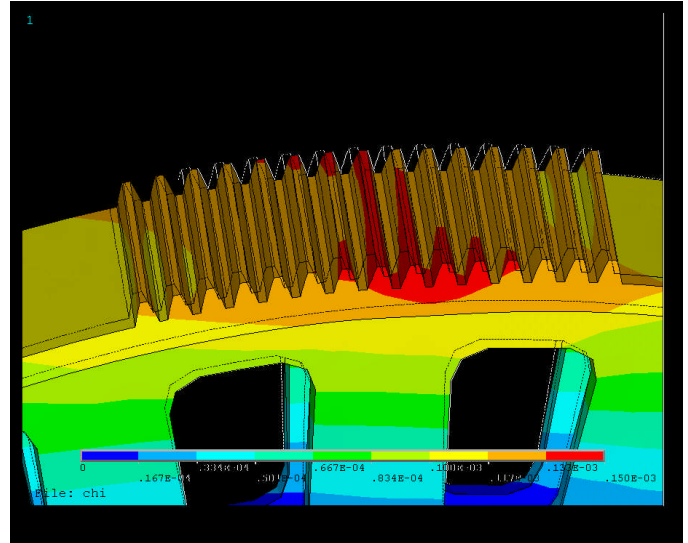

Figure 3b. Gear Tooth (Magnified 3a).

Inspection & testing – international standards

CITIC HIC manufacturers over a hundred gear sets every year and all activities are done in house from casting, forging, heat treatment, carburizing, machining, gear cutting, shop assembly and transport to ports of exports. This includes inspection and test plans for all major items which follow international ASTM & ISO standards with a large team of NDT and inspection supervisors for all equipment and components manufactured yearly.

MANUFACTURE

Ten gear cutters available at a single works include 2 x Ø5m, 3 x Ø8m, 1 x Ø10m, 1 x Ø12m, 1 x Ø13m and 2 x Ø16m (one in climate control). The gear hobber has the capacity to cut gears as large as 16m (52 ft) in diameter and weighing up to 250 tons. The gear width for straight teeth can be up to 1800mm (70 in). The machine is CNC controlled in 6 axis. The most significant advantage of a CNC gear hobbing machine against its traditional mechanical gear hobbing models is that the gear cutting production time can be shortened significantly (about 5-10 times faster), because for CNC models, the carbide tipped hobs with approximately 160 m/min surface speed can be utilized verses only the 16 m/min HSS-cutters for the traditional mechanical models. The CNC machines have additional advantages over mechanical units, for example, the production of gears can be programmed and recorded within the CNC control system, which can be used competitively; manufacturing gears of more complicated shapes, such as spiral bevel gears; the structure of the machine is simplified and it is easier for operation and maintenance.

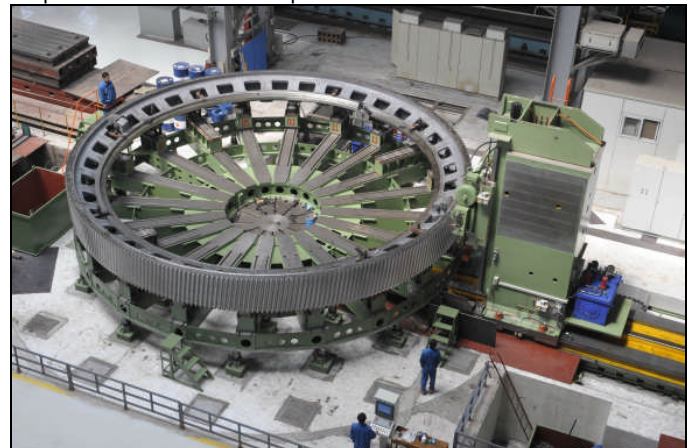

Figure 4. 16m CNC Gear Cutter.

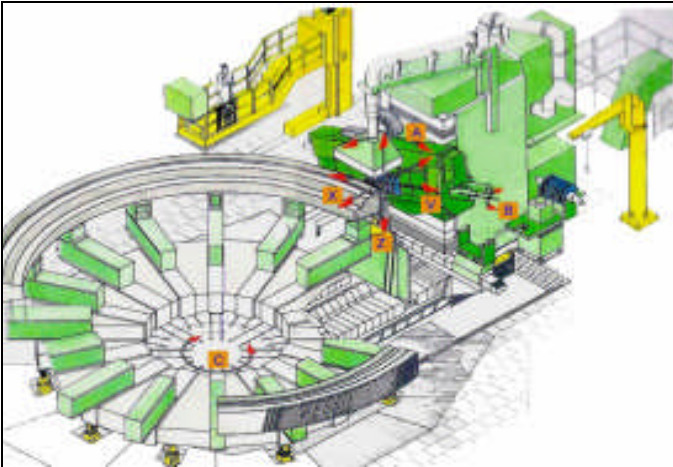

Figure 5. 16m CNC Gear Cutter (Six Axis).

Gear Castings are first run on MAGMA software utilizing full ring risers for solidification and cooling. Details are shown in figures 6 and 7. Using this method requires that the actual metal pour of casting to be approximately 2.5 times the net weight of the ring gear. For example, figure 8 illustrates a molten pour of 375t for a finished weight of a gear of 118t. The full ring gears are normally poured in a single piece even though they may be in quarters. This way it ensures that the complete gear has the same chemical analysis and it provides an even hardness when heat treated. Molten pouring capacity is up to 600t and hence we can do net gear casting weights of 250t.

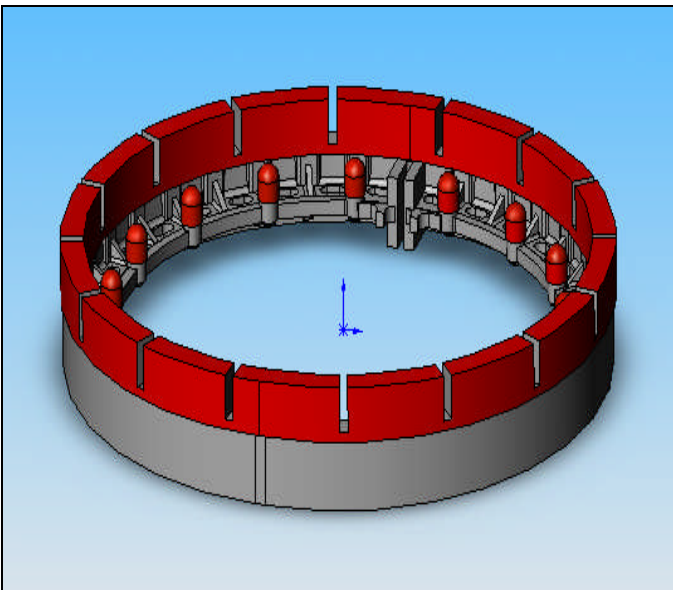

Figure 6. Casting Techniques.

Presently the gearless drive is more costly than the complete mechanical portion (mill rotating element and accessories supplied by the mill manufacturers) and hence the customer/consultant needs to have two parties to deal with from the start of any project. There is an interface between the mill vendor and the gearless motor supplier. Figure 9 shows the mechanical interface data required to be exchanged with the client being the mediator for any issues. After award to both parties (which must be done at the same time) there is a time period of up to 6 weeks in getting certified data from Gearless drive supplier (Siemens or ABB) before the mill vendor can start the FEA & basic design work which takes a further 6/8 weeks. This is not the case for mills with geared drive as engineering can commence immediately by the mill vendor.

Gearless drive rotating elements are heavier in construction than an equivalent gear drive grinding mill. The cast heads are heavier with

a longer flange to hold the segmented poles. The total weight of the poles are approximately 20% heavier in weight and need to be individually installed after the rotating element is put in place on the foundation. The foundation and load data on gearless drives are higher. See the typical forces in Figure 10, air gap variation is a source of magnetic pull imbalance. The exact run out is needed to reduce the risk of unbalanced magnetic pulls around the circumference. After mounting the poles, the tolerance for the run out over the complete circumference is inside of 0.5 mm. During actual operation the air gap on the top increases and it reduces at the bottom thus causing unbalance magnetic pull. The poles are mechanically connected and rotate with the mill which also requires preventative maintenance work.

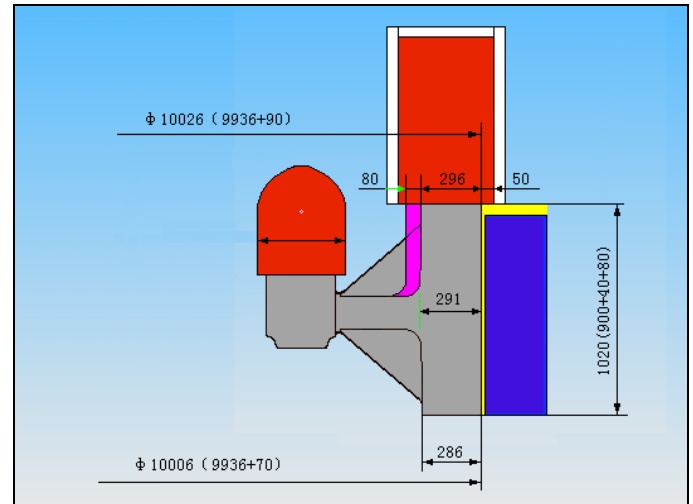

Figure 7. Casting Techniques.



Figure 8. 375 Tonne Molten Steel Gear Casting Pour.

All these things add significant cost to the overall cost for the client when compared to gear driven mills.

Real Estate and Civil Requirements

Here we compare both the Real-estate area and the Civil requirements for a Ø 7.9m x 14.2m LG geared and gearless driven Ball Mill. In this case the GMD requires slightly less space but it does require more concrete. Refer to Figures 11 through 14 below.

The actual concrete foundations for geared (Fig 13 & 14) and gearless drives (Fig 12) have also been compared (above ground level). Gearless drive foundations require a minimum height of approximately 8.9m to the mill center line. Much higher than for a geared drive at approximately 7m. This results in the GMD requiring higher volumes (and therefore civil cost) when compared to a WRIM drive requiring less concrete.

28MW, Ø12.2m Variable Speed AG Mills and 6 off 15.6MW, Ø7.9m dual pinion fixed speed Ball mills.

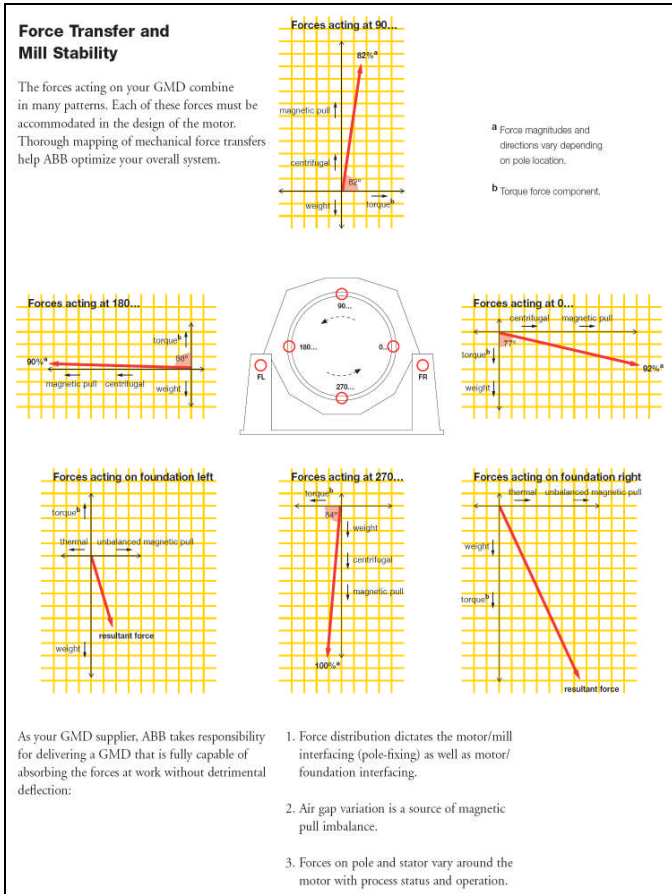

Figure 9. Force transfer on Gearless Drives.

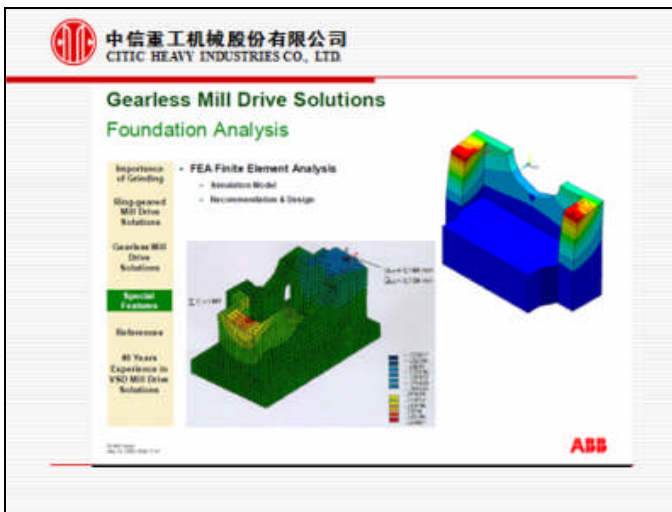

Figure 10. Gearless Mill Drive Foundation Analysis.

It is true the GMD drive does not require the real-estate for Motor, Pinion and Gearbox Lube systems however this area is easily off-set by the space needed for the GMD E-House.

In summary the Real-estate and Civil requirements of Geared Drive options compared to GMD's are very similar overall and in most cases would not form a deciding factor.

RESULTS AND DISCUSSION

Drive system capabilities

The largest mills manufactured to date are for the SINO Iron Project in Western Australia. When fully completed there will be 6 off

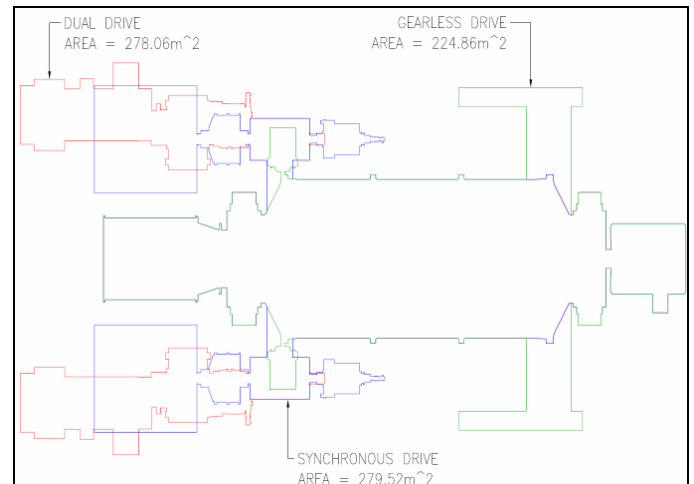

Figure 11. Space Requirement Comparison.

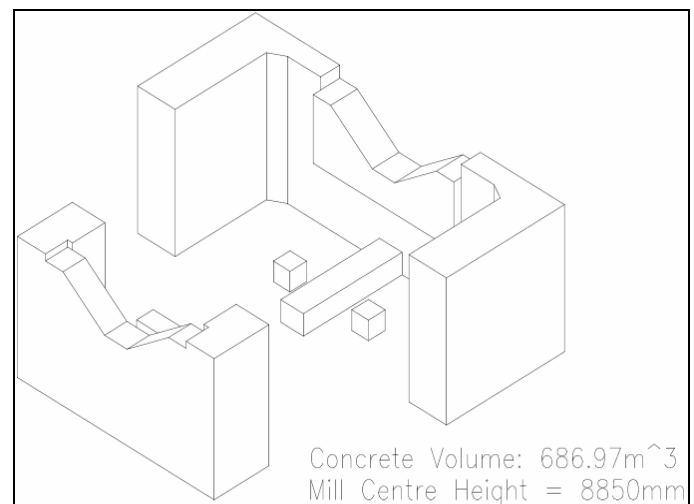

Figure 12. GMD Civil Requirement.

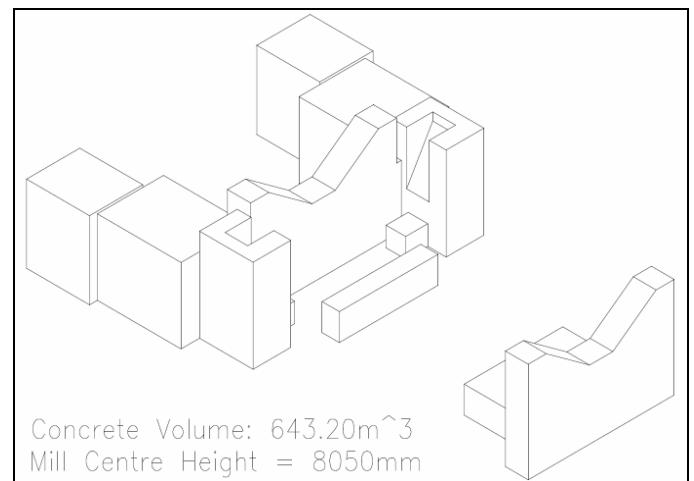

Figure 13. WRIM Civil Requirement.

There is presently the capability to manufacture gearless drives up to 35MW and present CITIC HIC manufacturing capabilities includes the fabrication of mill shells up to Ø13.7m mill (45ft) with no restrictions on casting and machining for these units.

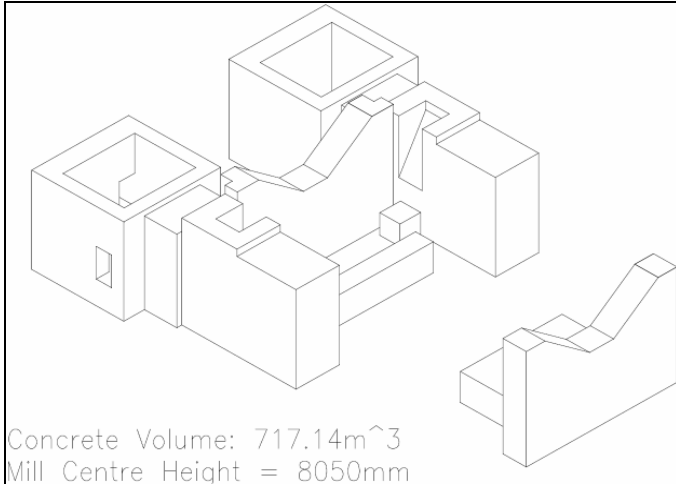

Figure 14. LSS Civil Requirement.

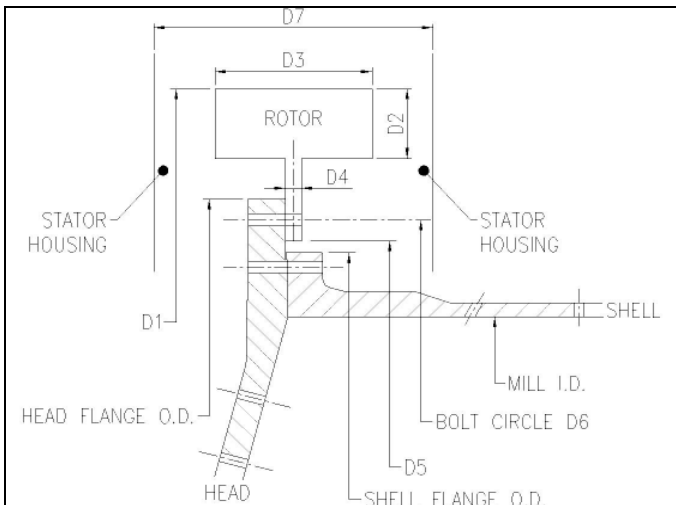

Figure 15. Mechanical Interface between Gearless Supplier and Mill Vendor.

GEAR DESIGN

		SAG Mill		Ball Mill	
Mill Diameter (m)		12.2		8.5	
Motor Power (MW)		20		20	
Motors		2 x 10 MW		2 x 10 MW	
Pinion Speeds (rpm)		160		150	
Mill Speed (rpm)		9.24		11.09	
		Pinion	Gear	Pinion	Gear
Number of teeth		21	344	21	288
Width of teeth (mm)		1080	1070	1080	1070
Normal Modulus (mm)		42		42	
Tool normal tooth profile angle (degrees)		25		25	
Helical Angle (degrees)		7.5		7.5	
Accuracy Level Number	ISO	5	8	5	8
	AGMA	12	9	12	9
Hardness of tooth face (BHN)	Brinell Hardness		310		300
	Rockwell hardness	57		57	
AGMA 6114 (min S.F)	Durability	≥ 1.75		≥ 1.75	
	Strength	≥ 2.5		≥ 2.75	
Actual Safety Factor to AGMA 6114	Durability	2.75	1.81	3.20	1.94
	Strength	2.52	2.52	3.20	2.62

This gives the following mill drive capabilities:

- GMD - Ball > 7.9m & SAG/AG > 11.5 m - >20MW
- Dual Pinion - Ball <8.5m & SAG/AG <12.3m up to 20MW
- Single Pinion - Ball < 7.4m / SAG/AG < 10.4m <10MW

Comparisons of efficiency in terms of electrical power consumed vs. mechanical output power

The efficiency of the drive system is made up of 2 major components, mechanical efficiency including the motor losses and the electrical efficiency including the electrical drive and its supporting components. If comparing only typical losses of the mechanical components alone it appears Gearless drive solutions outperform the Geared drive solutions however, this advantage changes when overall efficiency is taken into account.

All the below figures detailed in tables 1 through 4 are based on the averages of documented figures provided by vendors in datasheets or are derived from published papers (referenced in this paper). The following is a list of current projects using the various drive options referred above.

- Sino Iron – six 12.2m AG – 28MW GMD Drives
- Sino Iron – six 2x7.8MW Ball – Fixed HS Asynchronous with LRS
- Konkola Copper – 2.8MW + 5.5MW SAG – Variable HS Asynchronous with SER
- Konkola Copper Mines – 3.5MW + 2x5.5MW Ball – Fixed HS Asynchronous with LRS
- TISCO – four 2x5.5MW Ball + two 2x6.75MW Ball – Fixed LS Synchronous
- Jiangxi Copper – 2x5.5MW SAG + 2x5.5MW Ball – Fixed LS Synchronous
- MMX (Serra Azul) four Ball Ø7.9m – 2x8250kW WRIM
- Samarco - Four Ball Ø6.1m – 2 x 4,200kW,
- Wushan Copper Gold - SAG Ø11m – 2 x 6,325kW, Ball Ø7.9m LG – 2 x 8,500kW Low Speed Synchronous

Capital Cost

The Fixed speed Asynchronous LRS option is the lowest cost option, Table 4 uses this as a base price for comparison purposes. The capital costs are based on literally hundreds of mill estimates undertaken over many years for project around the globe.

Table 1. Variable Speed Drive Efficiencies.

	LS Sync + VVVF >24 pulse	GMD Cycloinverter	HS WRIM + SER	HS SCIM + VVVF >24 pulse
Harmonic Filter	100	99.5	100	100
Supply Transformer	100	100	99	100
VVVF Transformer	98.5	98.5	100	98.5
Recovery Transformer	100	100	99.8	100
VFD (incl cooling)	98.5	98.3	99.5	98.5
Motor (incl cooling)	95.7	95.1	95.4	95.9
Trunnion Lubricaton	98.8	98.8	98.8	98.8
Reducer (incl lube)	100	100	98.35	98.35
Ring Gear	99	100	99	99
SYSTEM EFFICIENCY	90.8	90.5	90.2	89.5

Running & Interest Costs

The main running cost by far is power. It can be easily calculated on a cost per kW (10c per kWh used for comparison basis in below tables) basis and the relative costs will be proportional to overall system efficiency as can be seen in the sample tables below. Girth gear and pinion lubricant have also been considered.

Initial capital cost saving are also significant. Not only in the capital saving itself but also in terms of the lost interest costs of more expensive drive options. It must therefore be considered. Using table 4 the lost interest costs for the more expensive drive options over the cheapest for either fixed or variable speed options has been considered using an annual interest rate of 8%. **Furthermore the initial extra capital paid is not recouped and therefore lost, this capital loss must be added to the losses detailed below in table 5.**

Table 2. Fixed Speed Drive Efficiencies.

	LS Sync + load share	GMD Cycloconverter	HS WRIM	HS SCIM + VVVF ≥24 pulse
Harmonic Filter	100	99.5	100	100
Supply Transformer	99	100	99	100
VVVF Transformer	100	98.5	100	98.5
Recovery Transformer	100	100	100	100
VFD/Load Share (incl cooling)	99.5	98.3	100	98.5
Motor (incl cooling)	95.7	95.1	95.4	95.9
Trunnion Lubricaton	98.8	98.8	98.8	98.8
Reducer (incl lube)	100	100	98.35	98.35
Ring Gear	99	100	99	99
SYSTEM EFFICIENCY	92.2	90.5	90.9	89.5

Table 3. Capital cost comparison (approx 10-20MW Mills).

	Approx. relative cost
Gearless Drive	Highest - 150%
Variable Speed Low Speed Sync	130%
Fixed Speed Low Speed Sync	125%
Variable Speed High Speed Asyn (VSI)	115%
Variable Speed High Speed Asyn (SER)	110%
Fixed Speed High Speed Asyn (LRS)	Lowest - 100%

Table 4. Cost comparisons for SAG mills.

20 MW Variable Speed SAG Mill				
COMPONENT	SAG MILL – VARIABLE			
	TWIN PINION DRIVE			GMD
	WRIM/SER	SYN	SCIM	GEARLESS
System efficiency	90.2%	90.8%	89.5%	90.5%
Lost power cost due to inefficiency	\$1,679,195	\$1,576,384	\$1,801,628	\$1,627,510
Gear Lubricant	\$130,000	\$130,000	\$130,000	\$0
Lost interest due to extra capital cost	0	\$256,000	\$64,000	\$512,000
Total pa	\$1,809,195	\$1,962,384	\$1,995,628	\$2,139,510
Total EXTRA pa over cheapest	\$0	\$153,189	\$186,433	\$330,315
Over 20 years	\$0	\$3,063,784	\$3,728,660	\$6,606,310

Cooling requirements

For geared mills, air cooling is the most common form of cooling for motors and drives. For Gearless motors and large cyclo-convertors water cooling is used. The heat dissipation required for water cooling represents the motor and drive losses and is in the order of 4% of the drive rating for a gearless drive (e.g. for a 20MW drive approx. 800 kW of heat needs to be removed). The volume of water required is approx. 2lpm for each kW which for a 20MW drive represents approx. 1600lpm of cooled water. In order to provide this amount of cooled water a cooling tower or chiller is usually required in a closed loop system due to the lack of fresh water at most mine sites. This adds to the capital cost of the project (Approx. \$1 million for 20MW) and requires power to run adding to running costs (Approx. 480kW for 20MW), or conservatively 1600lpm of water is required on a continuous basis.

Installation and delivery time for mills 15MW and above

The girth gear is the longest lead time item on a geared mill at approximately 9 to 14 months, on a gearless mill the Gearless drive is the longest lead time item at 12 to 18 months. The installation time for a geared drive is approximately 12 to 16 weeks (or approx. 8000 man

hours), for a gearless drive it is approx. 10 to 12 weeks for the mill and an additional 10 to 15 weeks including specialists for joining the windings together for the Gearless drive making a total of 18 to 24 weeks (minimum 20,000 man hours). This increases the capital cost of the installation by a minimum US\$2 million and causes an additional 2 to 3 months to the project schedule. This does not include the additional time and costs associated with commissioning of a gearless drive vs geared drive.

Table 5. Cost comparisons for Ball mills.

20 MW Fixed Speed Ball Mill				
COMPONENT	BALL MILL – FIXED			
	TWIN PINION DRIVE			GMD
	WRIM/LRS	SYN	SCIM	GEARLESS
System efficiency	90.9%	92.2%	89.5%	90.5%
Lost power cost due to inefficiency	\$1,570,152	\$1,338,114	\$1,801,628	\$1,627,510
Gear Lubricant	\$130,000	\$130,000	\$130,000	\$0
Lost interest due to extra capital cost	0	\$256,000	\$64,000	\$512,000
Total pa	\$1,700,152	\$1,724,114	\$1,995,628	\$2,139,510
Total EXTRA pa over cheapest	\$0	\$23,962	\$295,476	\$439,358
Over 20 years	\$0	\$479,246	\$5,909,519	\$8,787,169

CONCLUSION

For mills above 12.2m in diameter or over 20MW of power there is currently no viable alternative to a gearless drive. For mills 12.2m or less in diameter and 20MW or under in power, gear driven systems offer a more viable alternative to gearless drives delivering nearly equivalent efficiency, much lower capital cost, easier installation, simpler cooling, shorter installation time and quicker (2 to 3 months) project overall startup schedule.

Table 6. Project Savings over 20 years – GMD vs. Geared.

	SAG Mill - 20MW	Ball Mill – 20MW
Capital Cost Saving	\$6.4m	\$8m
Running Cost Saving	\$6.6m	\$8.8m
Cooling Cost Saving	\$1m	\$1m
Installation Cost Saving	\$2m	\$2m
Total Saving Over 20years	\$16m	\$19.8m

NOTE: A similar paper was presented at Procemin 2010 in Santiago, Chile. This paper includes a number of significant updates.

REFERENCES

- Ahrens, M. & Gonser, J. (2006)** *Protection and Supervision Systems for Gearless Mill Drives*. University of British Columbia, Vancouver.
- Beckum, W. R., Unknown, The ring motor is 30 years old.** Krupp Polysius AG, Beckum/Germany.
- Danecki, C. & Kress, D. (1995)** *Grinding Mill Gear Drives for the Future*, IEEE Technical Conference, San Juan, Puerto Rico, June 1995.
- Danecki, C. (1996)** (updated version) *SAG Mill Drives: Girth Gears at 18,000 HP – Operation and Performance*. Mining and mineral Process Engineering, UBC, Vancouver.

5. **Dreher, M. (1998)** *The design of large gear tooth systems for drives in the cement industry.* ZKG International No. 6/98 Cement-Lime-Gypsum, Vol 51. Joinville.
6. **Frank, W. (1996)** *Gearless Drives Experiences and New/Future Developments.* Mineral and Process Engineering, UBC, Vancouver.
7. **Kress, D. F. & Hanson, D. L. (1989)** *Design Concept Through Operating Criteria,* University of British Columbia, Vancouver.
8. **Roper, G., Manueco, C. & Bradley, P. (2006)** *Application of the Hyper Ser Drive to Sag Mills.* University of British Columbia, Vancouver.
9. **Schachter, N. (1998)** *Experience with Synchronous and Slip Ring Induction Motors Driving Cement Mills.* CIMENTEC Engineering Ltd, IEEE Cement Industry.
10. Scheiss Brighton Website - <http://www.schiessbrighton.com>
11. **Thomas, P. D. F. (1989)** *Development of S.A.G. Mill motor Drives.* University of British Columbia, Vancouver.
12. **Frank, W. (1989)** *Design and Application of Gearless Drives.* Mineral and Process Engineering, UBC, Vancouver.
13. **IES (July 2010),** Reference List of Mill Drives supplied by International Electronics S.A. Spain Rev.